

RETAINING BLOCKS

Block Library

28" (710mm) PC TOP

Face Texture:	Cobble / Limestone	Ledgestone
Block Weight:	1167 lb (529 kg)	1096 lb (497 kg)
Block Volume:	8.16 ft ³ (0.231 m ³)	7.66 ft ³ (0.217 m ³)
Center of Gravity:	15.3" (388 mm)	14.6" (372 mm)

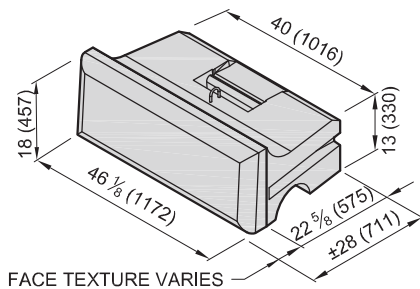

41" (1030mm) PC TOP

Face Texture:	Cobble / Limestone	Ledgestone
Block Weight:	1627 lb (738 kg)	1556 lb (706 kg)
Block Volume:	11.38 ft ³ (0.32 m ³)	10.88 ft ³ (0.31 m ³)
Center of Gravity:	21.8" (554 mm)	21.1" (536 mm)

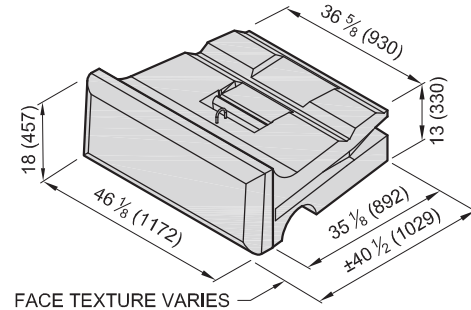

28" (710mm) PC MIDDLE

Face Texture:	Cobble / Limestone	Ledgestone
Block Weight:	1518 lb (689 kg)	1447 lb (656 kg)
Block Volume:	10.62 ft ³ (0.301 m ³)	10.12 ft ³ (0.287 m ³)
Center of Gravity:	14.2" (360 mm)	13.6" (346 mm)

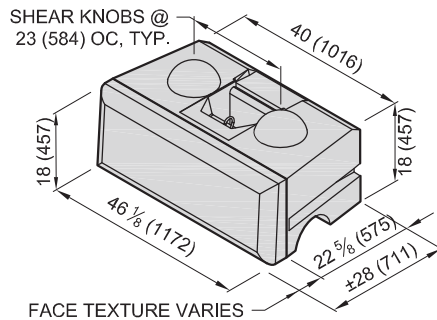

41" (1030mm) PC MIDDLE

Face Texture:	Cobble / Limestone	Ledgestone
Block Weight:	2172 lb (985 kg)	2101 lb (953 kg)
Block Volume:	15.2 ft ³ (0.43 m ³)	14.69 ft ³ (0.42 m ³)
Center of Gravity:	20.6" (522 mm)	20.0" (508 mm)

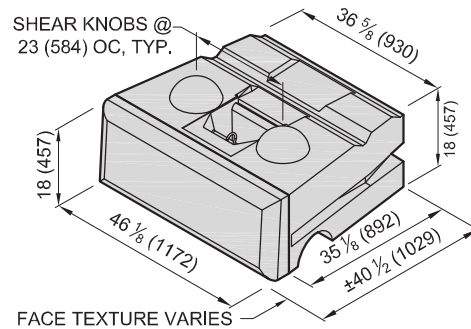

28" (710mm) PC BOTTOM

Face Texture:	Cobble / Limestone	Ledgestone
Block Weight:	1622 lb (736 kg)	1551 lb (703 kg)
Block Volume:	11.34 ft ³ (0.321 m ³)	10.85 ft ³ (0.307 m ³)
Center of Gravity:	14.2" (362 mm)	13.7" (349 mm)

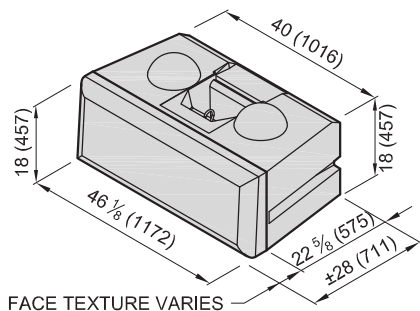

41" (1030mm) PC BOTTOM

Face Texture:	Cobble / Limestone	Ledgestone
Block Weight:	2276 lb (1032 kg)	2205 lb (1000 kg)
Block Volume:	15.92 ft ³ (0.45 m ³)	15.42 ft ³ (0.44 m ³)
Center of Gravity:	20.2" (514mm)	19.7" (501mm)

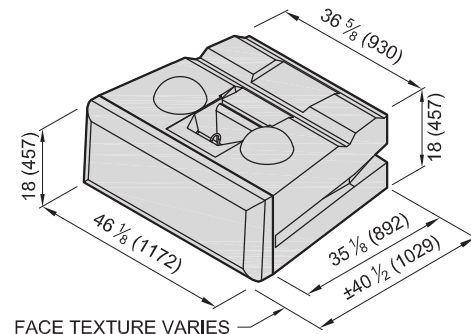

1. Units for dimensions are inches (mm), typical unless noted otherwise.
2. Confirm block production with licensed Redi-Rock manufacturer.
3. Center of Gravity is measured from the back of block.
4. Actual block volumes and weights may vary.
5. Weights are based upon a concrete density of 143 lb/ft³ (2291kg/m³).

6. Blocks contain a vertical slot for a 12" (300 mm) strip of geogrid soil reinforcement.
7. Interface Shear knobs are typically 10" (254mm) diameter by 4" (102 mm) tall. Smaller knob diameters are available.